

WH-25/30G

GALVANISED HAND PALLET TRUCK

- ◆ All the exposed parts of the whole truck galvanized, including hydraulic pump, fork frame, handle and so on.
- ◆ Special application in cold and wet environments resists the effects of cold, condensation and washing.

MODEL		WH-25G		WH-30G		
FEATURE						
1.1	Capacity	kg	2500		3000	
1.2	Pump Type		AC Pump		AC Pump	
WHEEL						
2.1	Wheel Type		Nylon		Nylon	
2.2	Size of load wheel(single)	Φd mm	80x93	74*93	80x93	74*93
2.3	Size of load wheel(tandem)	Φd mm	80x70	74*70	80x70	74*70
2.4	Size of steering wheel	ΦD mm	200x50	180*50	200x50	180*50
DIMENSION						
3.1	Size of fork	S mm	160x60		160x60	
3.2	Min. fork height	H1 mm	85	75	85	75
3.3	Max.fork height	H mm	200	190	200	190
3.4	Lifting height	h mm	115	115	115	115
3.5	Fork overall width	W mm	540/685		540/685	
3.6	Fork length	L mm	1100/1150/1220		1100/1150/1220	
3.7	Fork thickness	mm	3		3	
3.8	Weight	kg	72		82	

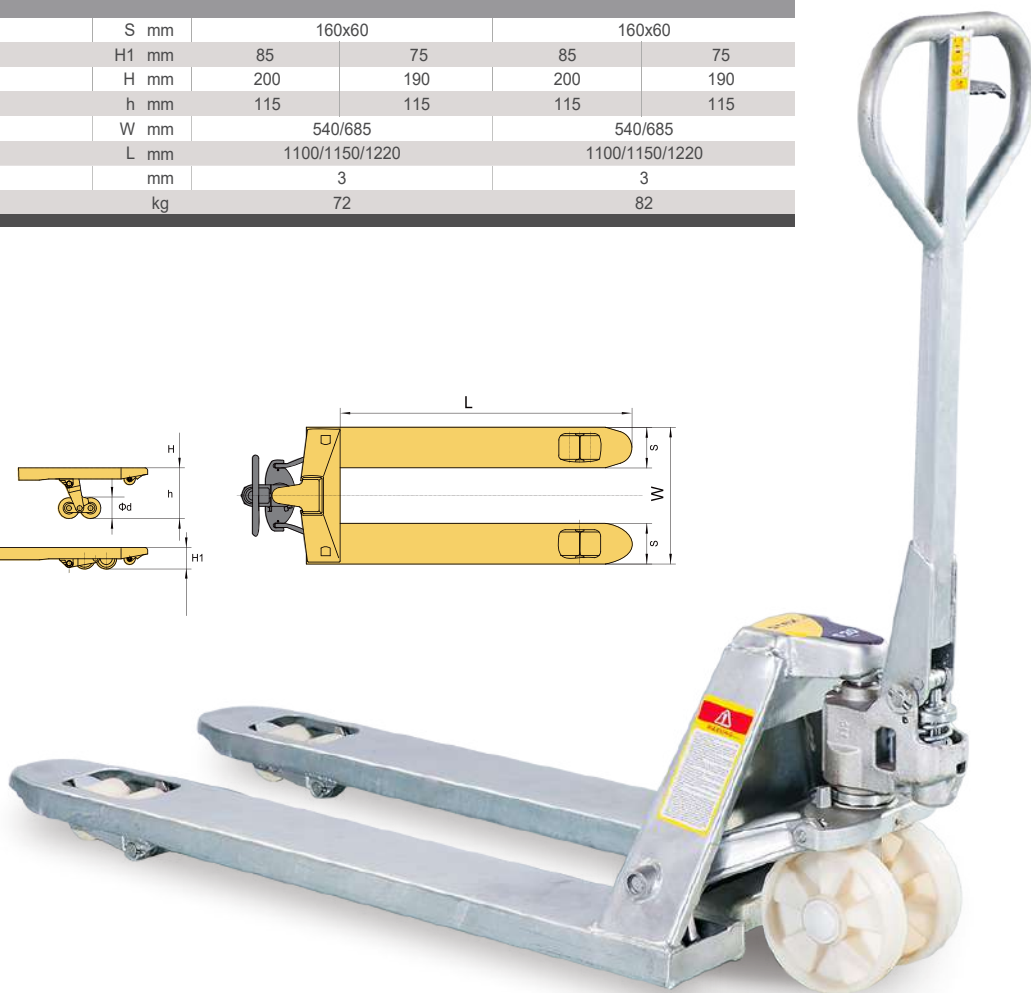
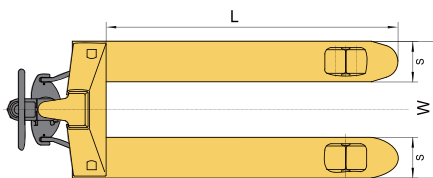
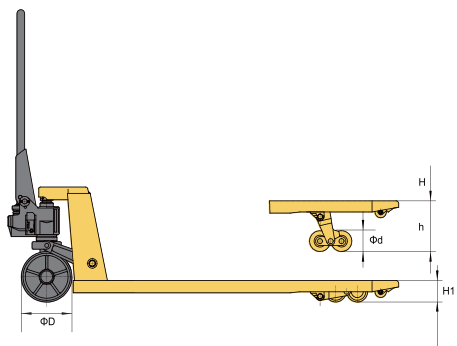

Hand Pallet Truck



- ◆ With pressure relief valve and overload valve to prevent pump damages when loads exceed weight limits.
- ◆ The one-piece pump design simplifies repairs, assuring reliable service and long life.



- ◆ Nylon fork rollers as standard option for damp or harsh environments applications.

